



PRISMA MINI BAR 20

SPECIFICATIONS / TECHNICAL DATA REV A

KEY FEATURES

IP65 Rated Exterior High-Power UV Wash Luminaire
Scoop LED Reflector Design
20 Degree Narrow Beam Angle
365nm Peak True UV Wavelength
Optional Black Glass Diffusion Filter



SPECIFICATIONS

Dynamic Effects

- . 20° Beam Angle
- . Variable Dim Modes (Via Pixel Driver 8)
- . High Speed Electronic Strobe
- . Beam Uniformity
- . (10) 3W High Power UV Diode Led's
- . 20,000 Hour Average Led Life

Control (Via Pixel Driver 8)

- . RDM (Remote Device Management)
- . Art-Net Protocol Support
- . Primary/Secondary Modes
- . On-board 4 Button Touch Control Panel

Connections

- . 9 ft (2.74m) 2-Conductor 14 Gauge IP Rated Power/Data Pigtail Cable Attached

Construction / Physical / Performance

- . Dimensions (LxWxH): 3.97" x 18.9" x 4.19" / 100 x 480 x 106.5mm
- . Weight: 4.2lbs. / 1.9kg

Electrical

- . Input Voltage: DC 0-36.7V
- . Power Consumption: 24.3W



PRISMA MINI BAR 20

SPECIFICATIONS / TECHNICAL DATA REV A

Certifications / Qualifications / Thermal

- . IP Rating: IP65 Rating
- . Approvals: ROHS, CE Approved
- . Cooling: Air Cooled
- . Maximum Temperature (Ambient): 113° F (45° C)
- . Minimum Temperature (Ambient): 14° F (-10° C)

What's Included

- . Phoenix Connector (x1)
- . Positive Wire Tip Sheath (x1)
- . Negative Wire Tip Sheath (x1)

Optional Accessories

- . Prisma Mini Bar 20 Black Glass (PSG820)

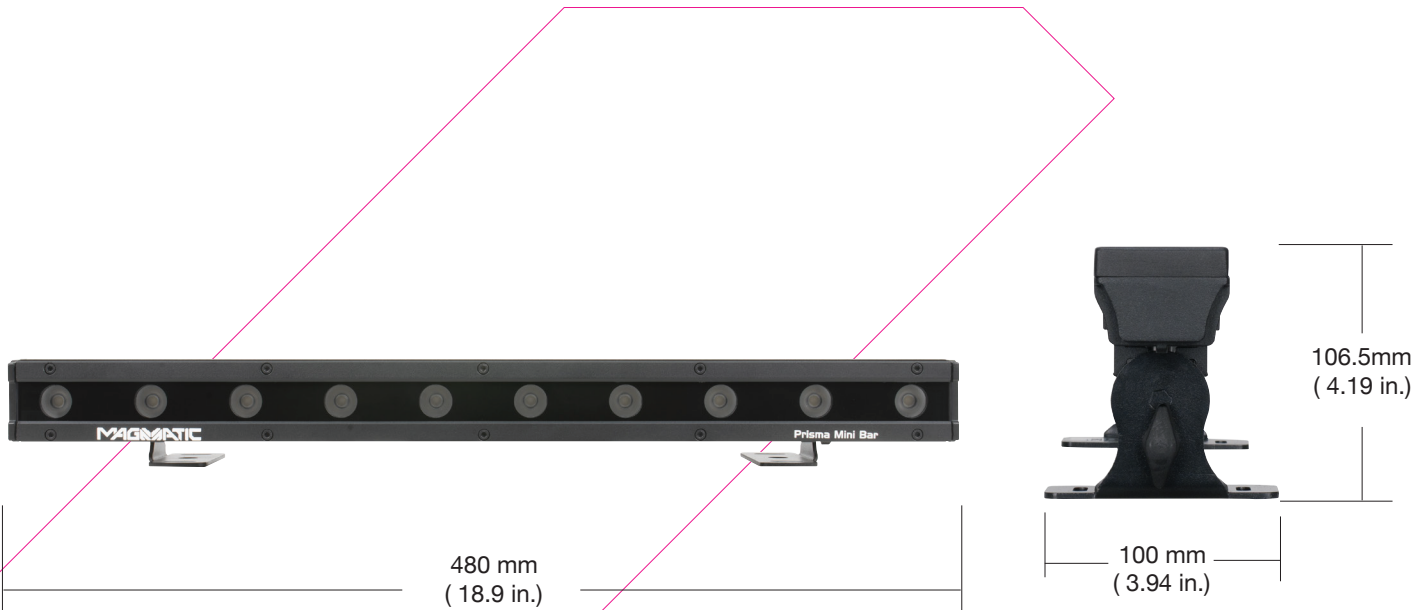

MAGMATIC